

INSTRUCTION AND MAINTENANCE MANUAL



3-Axis Vibration Tester RVM-4101

INSTRUCTION MANUAL

1. FEATURES

- * Uses piezoelectric acceleration transducer to convert vibration signal.
- * In accordance with ISO 2954,GB13823.3, used for periodic measurements, to detect out-of-balance,misalignment and other mechanical faults in rotating machines.
- * Specially designed for easy on site vibration measurement of all rotating machinery for quality control, commissioning, and predictive maintenance purposes.
- * 3 accelerators in 1 sensor for 3-axis vibration measurement.
- * 3 same parameters in one display for 3 dimensional measurement or 1 dimensional measurement specified, showing 3 different parameters of velocity, acceleration and displacement in 1 display.
- * Bearing condition monitoring function.
- * LCD digital display with back light.
- * Lightweight and easy to use.
- * Wide frequency range (10Hz.~10kHz.)
- * Automatic power shut off to conserve power.
- * AC output socket for headphones and recording.
- * Optional headphones for use as electronic stethoscope.
- * Optional software and cable for RS232C.

2. TECHNICAL PARAMETERS

Vibration Sensor: 3-Axis Piezoelectric accelerometer
 Display: 4 digit LCD backlit
 Axial Vibration: any one axis of X , Y, Z or 3 axes of XYZ
 Accuracy: $\pm(5\%n+2)$ digits

Measurement Range:

Displacement: 0.001-4.000mm Equivalent Peak-Peak; 0.04-160.0 mil ,
 Acceleration: 0.1-400.0 m/s² Equivalent Peak; 0.3-1312 ft/s²; 0.0-40g
 Velocity: 0.01-400.0 mm/s True RMS; 0.004-16.00 inch/s

Frequency Range:

Displacement: 10Hz. ~ 1kHz.
 Acceleration: 10Hz. ~ 10kHz
 Velocity: 10Hz. ~ 1kHz.

Metric/ Imperial conversion

Analogue Output: AC output 0~2.0V peak full scale(load resistance: above 10k)

With Max. value hold and low battery indication

PC interface: RS232C (Cable and software is not included)

Power off : Manual off at any time or auto power off is enabled by user

Operating conditions:

Temperature : 0-50° C
 Humidity : below 95% RH

Power supply: 2x1.5vAA (UM-3)Battery

Size: 130x70x30mm

Weight: 305g (Not including Batteries)

Standard Accessories:

- * Powerful rare earth magnet1pc.
- * 3 Piezoelectric accelerometers in 1 sensor1pc.
- * Stinger probe (Cone)1pc.
- * Stinger probe (Ball)1pc.
- * Carrying case1pc.
- * Operational instruction manual1pc.

Optional Accessories:

- * Headphones for use as electronic stethoscope
- * Cable and software for RS232C or USB
- * Bluetooth

E. Troubleshooting

Vibration frequency	Most possible reason	Other possible reason	Note
Synchronous with f_s *	Imbalance	1. Eccentric of gear, belt sheave and bush. 2. Shaft is not in the middle or curving (if vibration on the shaft direction is high). 3. Belt fault 4. Syntony 5. Reciprocate force	
Double f_s	Mechanical loose	1. Shaft is not in the middle or curing (if vibration on the shaft direction is high). 2. Belt fault 3. Syntony 4. Reciprocate force	
Triple f_s	Not in middle		
N multiple of f_s	Gear fault, liquid force, mechanical loose, reciprocating force.	1 x N x f_s (N is the tooth number of the fault gear). 2 x N x f_s (N is the paddle number of the fault pump or fan).	If loose is worse, there maybe higher multiple frequency.
$< f_s$	Oil film eddy turbulence	1. Drive belt fault 2. Interferential vibration 3. Beat frequency	
Synchronous with power frequency	Armature fault	Electric fault such as rotor broken, rotor eccentric, there phase imbalance and air clearance not symmetry.	
Double the power frequency	Torsional impulse		Seldom
High frequency (not multiple of f_s)	Shaft is not lubricate	1. Cavitations and turbulent flow. 2. Frictional force.	Amplitude and frequency of vibration are always not steady

* Is the frequency according with the rev of main shaft.

Note:

(1)“Class I” is small motor (power less than 15 kw). “Class II” is medium motor (power between 15 ~75kw). “Class III” is high power motor (hard base). “Class IIII” is high power motor (stretch base).

(2)A,B,C,D are vibration Rank. “A” means good, “B” means satisfying, “C” means not satisfying, “D” means forbidden. Vibration velocity should be taken from the three perpendicular axes on the motor shell.

B. ISO/IS2373 Motor quality standard according as vibration velocity

Quality rank	Rev (rpm)	H: high of shaft (mm)		
		Maximum vibration velocity (rms) (mm/s)		
		80 < H < 132	132 < H < 225	225 < H < 400
Normal	600~3600	1.8	2.8	4.5
Good (R)	600~1800	0.71	1.12	1.8
	1800~3600	1.12	1.8	2.8
Excellent (S)	600~1800	0.45	0.71	1.12
	1800~3600	0.71	1.12	1.8

Limit of rank “N” is suitable for common motor. When the request is higher than that in the table, limit can be gotten by dividing the limit of rank 'S' with 1.6 or multiples of 1.6.

C. Maximum vibration of motor that power larger than 1 horsepower. (NEMA MG1-12.05)

Rev (rpm)	Displacement (P-P) (um)
3000~4000	25.4
1500~2999	38.1
1000~1499	50.8
≤999	63.6

For AC motor, rev is maximum synchronous rev. For DC motor, it is maximum power rev. For motor in series, it is work rev.

D. Maximum vibration of high power induction drive motor. (NEMA MG1-20.52)

Rev (rpm)	Displacement (P-P) (um)
≥3000	25.4
1500~2999	50.8
1000~1499	63.6
≤999	76.2

National Electric Manufacturers Association (NEMA) Establishes two standards above.

3. PARTS INTRODUCTION

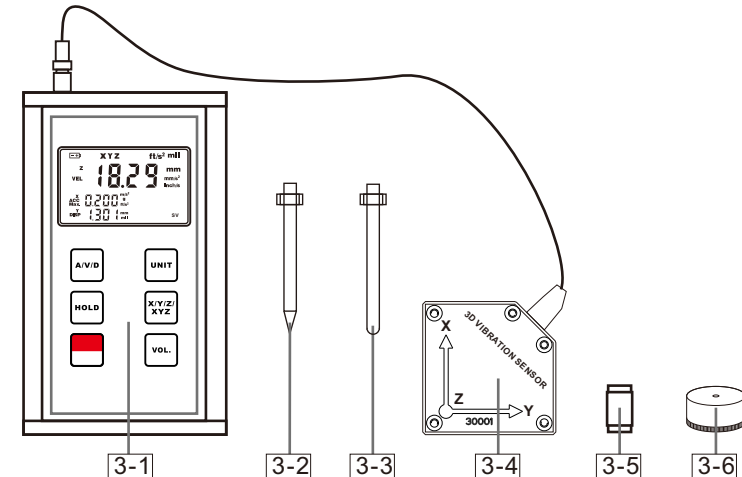

Figure 3.1

- 3-1 Main Body
- 3-2 Stinger Probe (Cone)
- 3-3 Stinger Probe (Ball)
- 3-4 3D Vibration Sensor
- 3-5 Bolt
- 3-6 Magnetic Base

According to different situations, the transducers maybe fixed in the probe or connected to the magnetic base. (see chapter 4 in detail)

4. DISPLAY INTRODUCTION

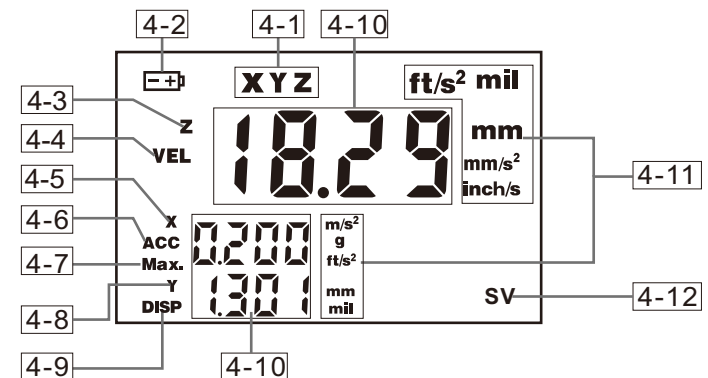

Figure 4.1

- 4-1 3-axis indication
- 4-2 Low battery indication
- 4-3 Z-axis
- 4-4 Velocity
- 4-5 X-axis
- 4-6 Acceleration
- 4-7 Max value hold
- 4-8 Y-axis
- 4-9 Displacement
- 4-10 Measuring value
- 4-11 Measuring unit
- 4-12 Auto power off is enabled

4.1 Installation Principle

- The testing position should show the vibration characters of the object to be tested.
- The main axis of the transducers should be consistent with the direction of the object to be tested
- The sensor should be in close contact with the object to be tested.

4.2 Install Method

Method Contrast	Install with Bolts	Install with Magnetic base	Install with Probe
Cost	None	Low	low
Affection on the result	None	When roughness is worse than Ra1.6, the result maybe not stable	When caring about acceleration and the vibration frequency is higher than 1KHz, the result will be smaller.
Convenience	Not good	Good	Best

4.2.1 Installed With Bolt

Application range: Screw eye has no influence on the running of the object being tested. Usage: Drill a screw eye 5mm deep in the object being tested. Connect the sensor to the object by bolts (see Figure 4.2). And this is the method that the frequency response is best.

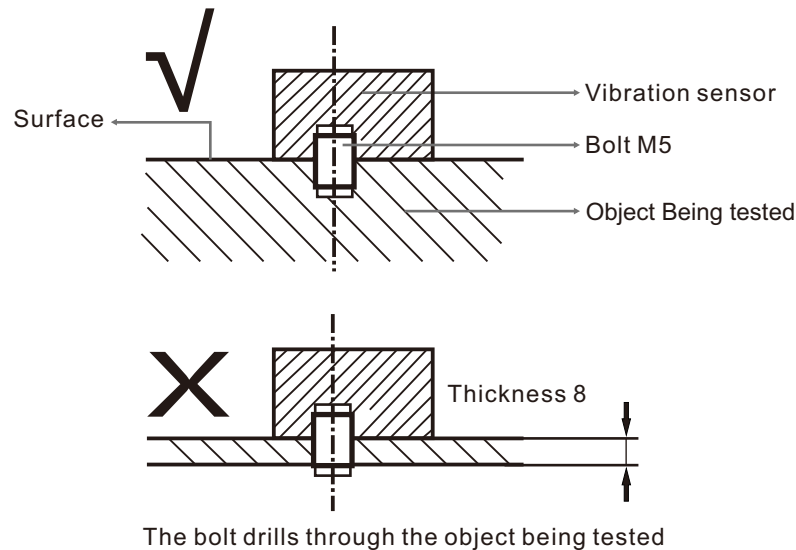

Figure 4.2

6.3 Measurement Techniques

In general, vibration of anti-friction bearings is best monitored in the load zone of the bearing. Equipment design often limits the ability to collect data in this zone. Simply select the Measurement Point which gives the best signal. Avoid painted surfaces, unloaded bearing zones, housing splits, and structural gaps. When measuring vibration with a hand-held sensor, it is very important to collect consistent readings, paying close attention to the sensor's position on the machinery, the sensor's angle to the machinery, and the contact pressure with which the sensor is held on the machinery.

. Location - always collect at the same point on the machine. Mark locations.

. Position - Vibration should be measured in three directions:

A axial direction; H horizontal direction; V vertical direction

Please define A, H, V as X, Y, Z axes respectively.

. Angle - Always perpendicular to the surface ($90^\circ \pm 10^\circ$).

. Pressure - Even, consistent hand pressure must be used (firm, but not so firm as to dampen the vibration signal). For best results, use the magnetic base. If using the stinger/probe is the only method available to collect data, it is best to use a punch to mark the location for the probe-tip to ensure a consistent coupling to the housing.

7. BATTERY REPLACEMENT

7.1 When the battery symbol appears on the display, it is time to replace the battery. 7.2 Slide the Battery Cover away from the instrument and remove the batteries.

7.3 Install batteries paying careful attention to polarity.

8. APPENDIX: VIBRATION STANDARDS

A. Rank of machine vibration (ISO 2372)

Vibration Amplitude Vibration Velocity V_{rms} (mm/s)	Machine sort				
	I	II	III	IIII	
0~0.28	A	A	A	A	
0.28~0.45					
0.45~0.71					
0.71~1.12	B	B	B	B	
1.12~1.8					
1.8~2.8	C	C	C	B	
2.8~4.5					
4.5~7.1	D	D	C	C	
7.1~11.2					
11.2~18					
18~28			D	D	D
28~45					
> 45					

times, causing costly production down time. As parts of mechanical equipment wear and deteriorate, the equipment vibration increases.

Monitoring the vibration of healthy mechanical equipment on an ongoing basis, detects any deterioration long before it becomes a critical problem, allowing spares to be ordered in advance and maintenance to be planned only when necessary. In this way stocks of expensive and unnecessary spares can be reduced with obvious financial benefits.

Unscheduled breakdowns result in production losses and the faulty equipment is usually repaired hastily to get production going as quickly as possible. Under these stressful conditions staffs are not always able to do repairs correctly regardless of how conscientious they are, resulting in a high probability of further early equipment failure.

By implementing a predictive maintenance program with regular measurements of critical factors like vibration, downtime can not only be reduced, but planned maintenance is more effective, resulting in improved product quality and greater productivity.

6.1 Which Parameters Should be Measured?

Acceleration, velocity, and displacement are the three tried and tested parameters, which give accurate and repeatable results?

Velocity is the most commonly used vibration parameter. It is used for vibration severity measurements in accordance with ISO 2372, BS 4675 or VDI 2056, which are guidelines for acceptable vibration levels of machinery in different power categories. See Appendix.

Acceleration has excellent high frequency measurement capabilities, and is therefore very effective for determining faults in bearings or gearboxes.

Displacement is typically used on low-speed machines because of its good low frequency response, and is relatively ineffective when monitoring bearings.

6.2 Evaluating the Overall Vibration Measurements

Three general principles are commonly used to evaluate your vibration measurement values:

ISO 2372 (10816) Standard Comparison - Compare values to the limits established in the ISO 2372 (10816) Standard.

Trend Comparison - Compare current values with values of Baseline for the same Point over a period of time.

Comparison with Other Machinery - Measure several machines of a similar type under the same conditions and judge the results by mutual comparison. If possible, you should use all three comparisons to evaluate your machinery's condition. ISO 2372 (10816) and trend comparisons should always be used.

ISO 2372 (10816) Standard Comparison

The ISO 2372 (10816) Standards provide guidance for evaluating vibration severity in machines operating in the 10 to 200 Hz (600 to 12,000 RPM) frequency range. Examples of these types of machines are small, direct-coupled, electric motors and pumps, production motors, medium motors, generators, steam and gas turbines, turbo-compressors, turbo-pumps and fans. Some of these machines can be coupled rigidly or flexibly, or connected through gears. The axis of the rotating shaft may be horizontal, vertical or inclined at any angle.

4.2.2 Installed With Magnetic Base

Application range: Magnetic, flat surface, roughness less than Ra1.6, acceleration less than 20m/s².

Usage: connect the vibration sensor with magnetic base with the M5 bolt included. And then place the magnetic base to the object to be tested. Please refer the below.

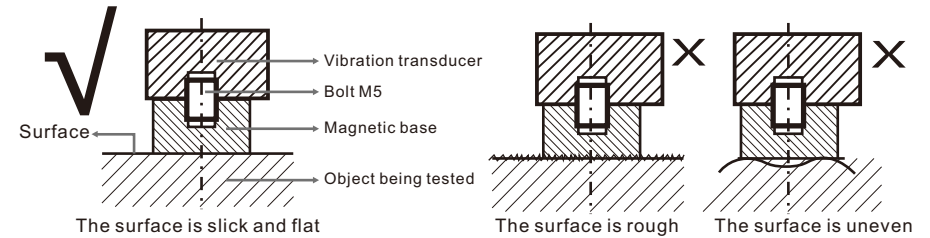

Figure 4.3

4.2.3 Installed With Probe

Applications Range: Frequency is less than 1KHz and vibration energy is not small. Usage: Connect the needle to the sensor directly by using probe groupware.(see Figure 4.4)

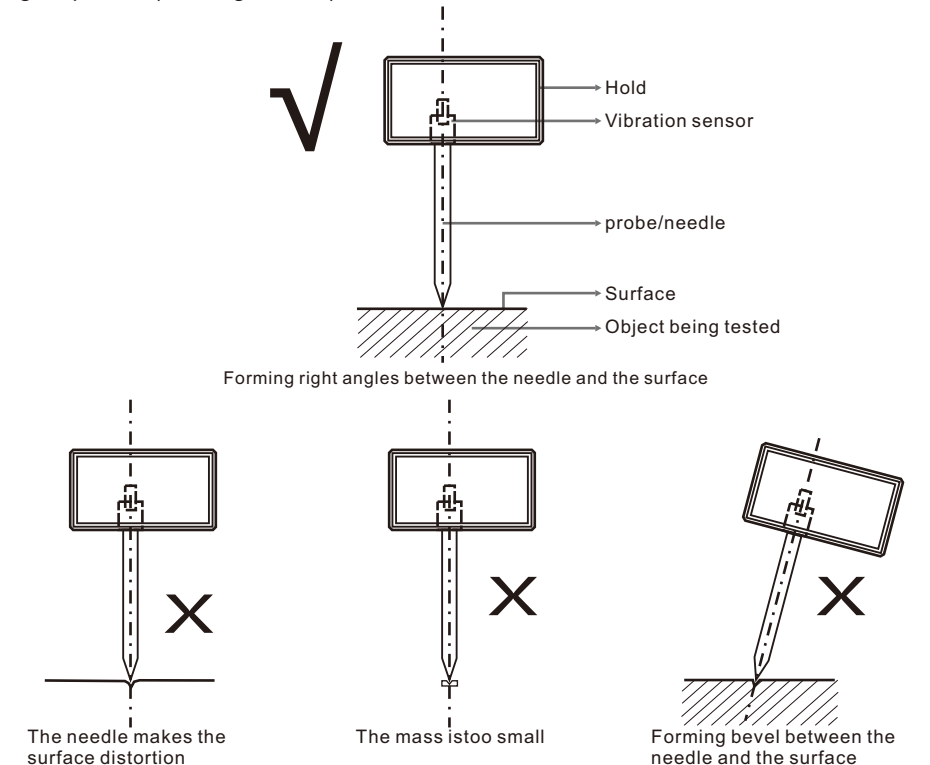
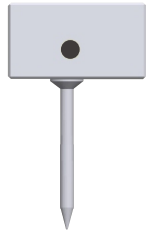

Figure 4.4

5. GETTING STARTED

5.1 Connecting the sensor

- Note that this meter accepts only the supplied vibration sensor.
- Plug the connector side of the sensor into the plug at the top of the meter.
- The sensor can be connected to the machinery under test in three ways. Please refer the blow.



Stinger Probe



Installed with bolt



Magnetic Base

5.2 Power ON-OFF

- Press the POWER button to turn the meter ON or OFF.
- The meter is equipped with an automatic power off utility that conserves battery life. If the meter is left inactive for 30 minutes it will automatically turn off. The automatic power off utility is enabled or disabled by pressing and hold the volume key for 5s. The symbol 'SV' showing on the display indicates auto power off utility is enabled. Otherwise, disabled if not showing 'SV'.

5.3 How to set coordinate axis

There are 4 choices of X, Y, Z, XYZ. Any one coordinate axis of X or Y or Z with 3 parameters of velocity, acceleration and displacement showing on one display can be selected. Or 3-axis of X-Y-Z with any one parameter of velocity or acceleration or displacement can be selected. The currently selected coordinate axis is shown on the meter's LCD. Every time to press the X/Y/Z/XYZ key, the selected axis is changed. Please pay attention to the axes marked on the 3 dimensional sensor. See below.

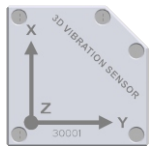

Front (A)



X (B)

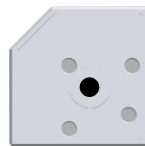

Z (C)



Y (D)

5.4 Function Selection

Function key is only valid in the 3-axis mode and used to select the parameter to be measured. The currently selected parameter is shown on the meter's LCD. To change the parameter, just press and release the FUNCTION key.

- ACC means 'Acceleration' measurement mode.
- VEL means 'Velocity' measurement mode.
- DISP means 'Displacement' measurement mode.

5.5 Unit Conversion

The currently selected unit of measure is shown on the meter's LCD. To change the unit of measure, press the UNIT key.

FUNCTION	UNIT	NOTE
VEL (RMS)	mm/s	millimeters per second
	Inch/s	inch/s inches per second
ACC (Peak)	m/s ²	meter per second squared
	g	g-force
	ft/s ²	feet per second squared
DISP (Peak-Peak)	mm	millimeters
	mil	one thousandth of an inch

5.6 MAX HOLD

To freeze maximum values, just press the Hold key, a symbol 'Max' shows on the display. The meter will hold the max value measured. To exit HOLD, press the HOLD key again.

5.7 Filter (only valid in acceleration mode)

To diagnose faulty bearings, the high frequency 10k mode (acceleration only) is used, and by using the optional headphones, the instrument can be used as an electronic stethoscope and noise from abnormal bearings can be monitored.

5.8 Analogue output

This AC signal can output to recorder or headphone to listen for any distinct patterns or noises. Listening method will help to locate the defective machinery or bearing quickly. Measure all machines at the same points and compare the results. The sound volume can be adjusted by Volume key. There are 8 levels from 1 to 8 to select. The level 1 is the lowest amplitude while the level 8 is the maximum amplitude of output signal. To exit volume setting, simply wait 5s for the meter to automatically switch to the normal measuring mode.

5.9 RS-232 Serial PC Interface

The meter is equipped with an RS-232 serial data port. This interface was designed to operate with the Data Acquisition Software and enables the user to capture, store and display readings on a PC. USB and Bluetooth can also be available via RS232C interface.

6. AN INTRODUCTION TO VIBRATION MEASUREMENT

Vibration is a reliable indicator of the mechanical health or condition of a particular machine or product. An ideal machine will have very little or no vibration indicating that the motor, as well as peripheral devices such as gearboxes, fans, compressors, etc., are suitably balanced, aligned, and well installed. In practice, a very high percentage of installations are far from ideal, the results of misalignment and imbalance exerting added strain on supporting components such as bearings. Eventually this leads to added stress and wear on critical components, resulting in inefficiency, heat generation and breakdowns. This often occurs at the most inconvenient or uneconomical